

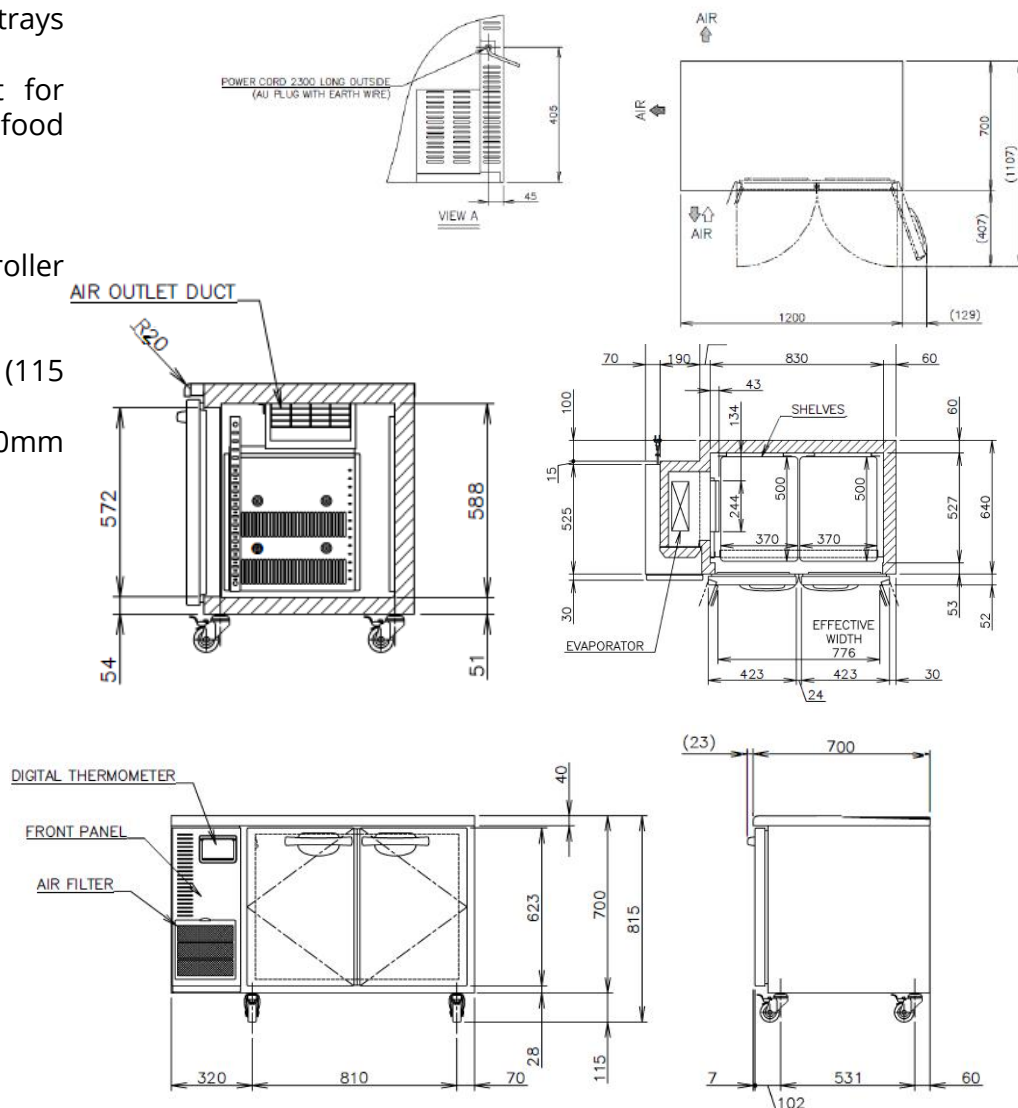

PRODUCT FEATURES

- With no centre pillar you can use trays and containers of varying sizes.
- This Pillar Less range is perfect for kitchens looking to maximise their food storage.
- Complete with stainless steel top. Standard with 4 shelves / 2 doors.
- Programmable electronic controller and display.
- 2 years parts and labour warranty.
- Comes standard with 4 x lockable (115 mm) castors (not legs).
- Optional Adjustable legs 150 - 180mm (Sold separately).

TECHNICAL DRAWING



PRODUCT SPECIFICATION

Exterior	Stainless Steel, Galvanized Steel (Rear /Bottom)
Interior	Stainless Steel, ABS Plastic
Max Storage Capacity	265L
Temperature Control	Microprocessor controlled Adjustable from -25 to -7°C
Condenser	Fin & Tube type
Outside Dimensions	1200mm (W) x 700mm (D) x 815mm (H)
Inside Dimensions	830mm (W) x 527mm (D) x 588mm (H)
Refrigeration System	Forced Air Circulation
Weight Net/Gross (kg)	84 / 89
AC Supply Voltage	1 PHASE 220 - 240V 50Hz
Amperage	Rated: 2.5A Starting: 12.6A
Refrigerant Charge	R404A/200g
Operating Conditions	Ambient Temp.: 5-43°C Voltage Range: Rated Voltage ±6%



Descriptions and specifications are subject to change at any time, without notice. Illustrations for demonstration purposes.

Copyright © 2019 Hoshizaki Lancer Pty Ltd. All right reserved. E&OE Date: May 2019