



PRODUCT FEATURES

- Premium Cubelet ice.
- Smooth ice dispense.
- No ice bridging.
- Robust and reliable.
- Sanitary self-service application.
- Easy operation - Push button; dispense ice directly in to container greatly reducing risk of contamination.
- Dispenses ice only, water only or ice and water.
- Adjustable portion-controlled dispensing.
- Due to auger system water consumption is equal to ice production.
- 2 year parts & labour on entire unit, 5 year (parts only) on compressor & air cooled condenser coil.

SHAPE OF ICE:



TECHNICAL DRAWING

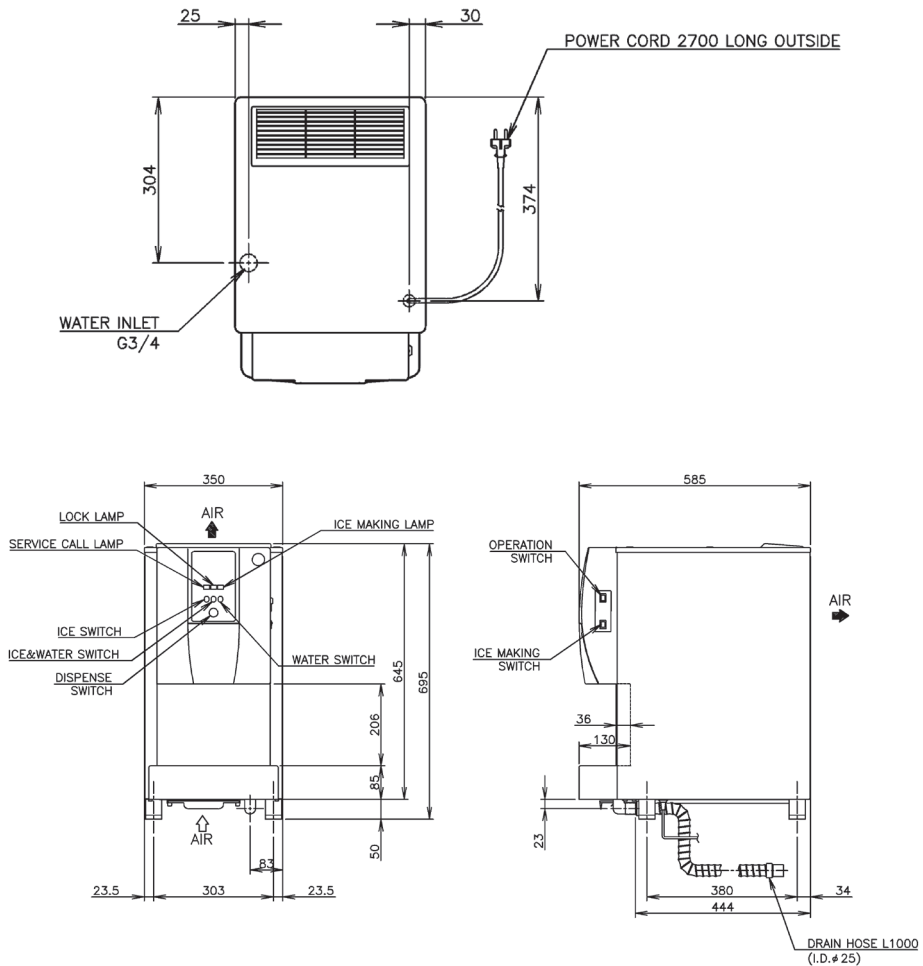

DCM-60KE-P

PRODUCT SPECIFICATION

| | |
|---------------------------------|---|
| Production Capacity per 24hours | Approx. 60kg @10°C Air temp; 10°C Water Approx. 50kg @ 21°C Air temp; 15°C Water Approx. 38kg @ 32°C Air temp; 21°C Water |
| Max Storage Capacity | Approx. 1.9kg |
| Dimensions | 350mm (W) x 585mm (D) x 695mm (H) |
| Cooling | Air |
| Weight Net/Gross (kg) | 47 / 56 |
| AC Supply Voltage | 1 PHASE 220 - 240V 50Hz |
| Amperage | Rated:1.5 A Starting: 9.5 A |
| Refrigerant Charge | R134a |
| Operating Conditions | Ambient Temp.: 5-40°C Water Supply Temp.: 5-35°C Water Supply Pressure: 0.07-0.8MPa Voltage Range: Rated Voltage ±6% |



Descriptions and specifications are subject to change at any time, without notice. Illustrations for demonstration purposes.

Copyright © 2019 Hoshizaki Lancer Pty Ltd. All right reserved. E&OE Date: May 2019