

1. Install the product properly in accordance with the instructions on location, water supply/drain connections and electrical connections stated in the instruction and installation manuals provided.
2. The ice production depends on the ambient and water temperatures. Refer to the instruction manual.
3. Product Code: F037, F039 (50Hz)
F038, F040 (60Hz)

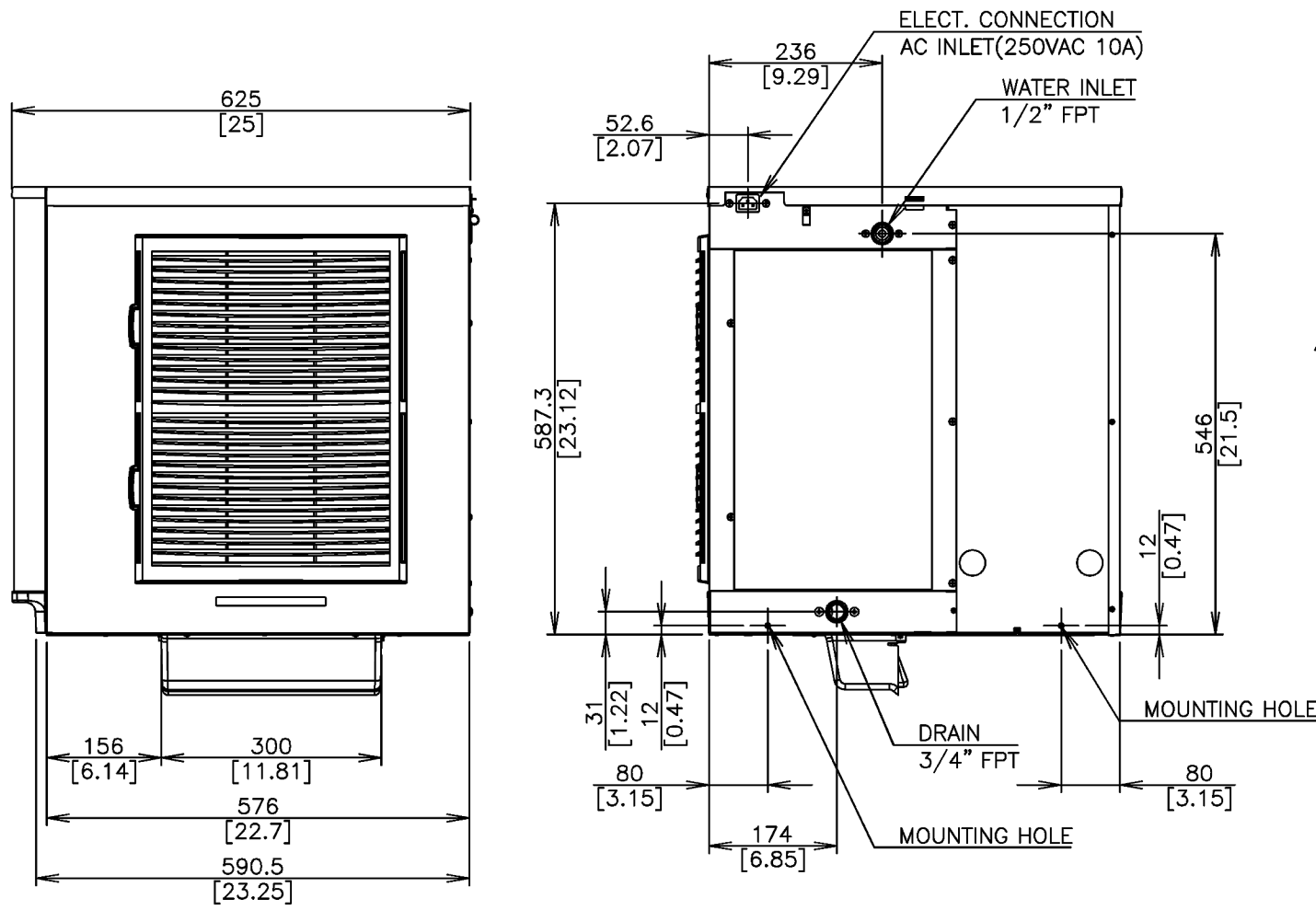
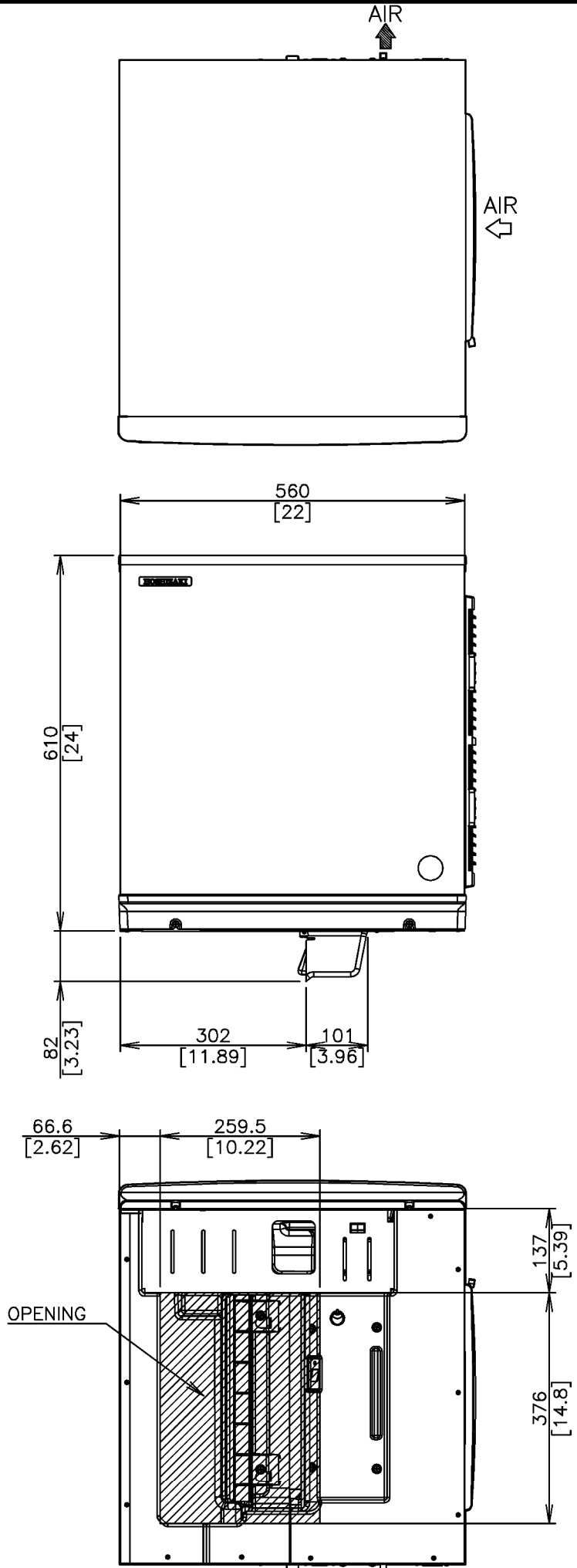

ITEM	Hoshizaki Crescent Ice Maker (Modular Type)
MODEL	KMD-201AA
AC SUPPLY VOLTAGE	1 Phase 220-240/230V 50/60Hz
AMPERAGE	3.0/3.6A(AT. 32°C, WT. 21°C)
STARTING AMPERAGE	25/25A
ELECTRICAL CONSUMPTION	700/810W(AT. 32°C, WT. 21°C)
POWER FACTOR	95/95%
POWER SUPPLY CAPACITY	Min. 1.57KVA(6.8A)
ICE PRODUCTION PER	Approx. 190/205kg/d(AT. 10°C, WT. 10°C) Approx. 167/182kg/d(AT. 21°C, WT. 15°C) Approx. 135/157kg/d(AT. 32°C, WT. 21°C)
WATER CONSUMPTION PER	Approx. 0.90/0.98m³/d(AT. 10°C, WT. 10°C) Approx. 0.40/0.48m³/d(AT. 21°C, WT. 15°C) Approx. 0.27/0.31m³/d(AT. 32°C, WT. 21°C)
SHAPE OF ICE	Crescent Cube
FREEZE CYCLE TIME	Approx. 30.6/27.7Min(AT. 21°C, WT. 15°C)
ICE PRODUCTION PER CYCLE	Approx. 3.8/3.8kg / 416pcs(AT. 21°C, WT. 15°C)
OUTSIDE DIMENSIONS	560mm(W) x 625mm(D) x 610mm(H)(not incl. Bin Sw)
EXTERIOR	Stainless Steel, Plastic Frame(Front), Galvanized Steel(Rear)
INSULATION	Polyurethane Foam
INSULATION FOAM BLOWING AGENT	Cyclopentane
CONNECTIONS-ELECTRIC	X-type Connection
CONNECTIONS-WATER SUPPLY	Inlet 1/2" FPT(connected at rear side)
CONNECTIONS-DRAIN	Outlet 3/4" FPT(connected at rear side)
ICE MAKING SYSTEM	Vertical Evaporator with water flow on both sides
HARVESTING SYSTEM	Water Supply Harvest Cycle and Hot Gas Defrost
COMPRESSOR	Hermetic
CONDENSER	Air-cooled, Fin and Tube type
HEAT REJECTION	1410W(1220kcal/h)(AT. 32°C, WT. 21°C)
EVAPORATOR	Vertical type, Stainless Steel and Copper
REFRIGERANT CONTROL	Thermostatic Expansion Valve
REFRIGERANT CHARGE	R404A/520g
ICE MAKING CONTROL SYSTEM	Float Switch
HARVESTING CONTROL SYSTEM	Hot Gas and Water, Thermistor and Timer
ICE MAKING WATER CONTROL SYSTEM	Timer Controlled, Overflow Pipe
BIN CONTROL SYSTEM	Mechanical Bin Switch
ELECTRICAL PROTECTION	Class I Appliance, 5A Fuse
P.C. BOARD CIRCUIT PROTECTION	High Voltage Cut-out(Internal)
COMPRESSOR PROTECTION	Auto-reset Overload Protector(External)
REFRIGERANT CIRCUIT PROTECTION	Auto-reset High Pressure Control Switch
LOW WATER PROTECTION	Float Switch
WEIGHT	Net weight 57kg / Gross weight 73kg
PACKAGE	Carton 668mm(W) x 727mm(D) x 793mm(H)
ACCESSORIES	Instruction Manual, Universal Brace, Bolt(2), Check Valve(-C121), Nipple(-C121), Power Cord-SE type plug(-C101), BF type plug(-C111), O type plug(-C121), B3 type plug(-C131), A(angled) type plug(-C141), A(parallel) type plug(-C151)
OPERATION CONDITION	Ambient Temp.: 7-40°C, Water Supply Temp.: 7-35°C Water Supply Pressure: 0.07-0.8MPa(0.7-8bar) Voltage Range: 198-254V

*We reserve the right to make changes in specifications and design without prior notice.

HOSHIZAKI CRESCENT ICE MAKER KMD-201AA (MODULAR TYPE)

APPROVED OGATA	CHECKED YOSHIDA	DESIGNED YAMAGUCHI	DRAWN MINEZAWA	SCALE 1/10	TRIGONOMETRY
SHEN	ZHANG	2016.02.18	DATE 2009.07.13	DRAWING NO. D05000	SYMBOL 3
APPROVED	DESIGNED	DATE			